



SIRENA 48



SIRENA YACHTS





SIRENA 48
DREAM VOYAGE

With the cruising capabilities and range of speeds expected of the marque, the Sirena 48 is a balance of elegance and practicality for the modern yachting enthusiast.

 **SIRENA 48**





SIRENA YACHTS

Exterior

Designer Quote

A Family Resemblance

In crafting the exterior design for the Sirena 48, we focused on capturing the essence of the line that has given Sirena its signature look, distinctive around the world. We added a touch of excitement with dynamic design elements, showcasing its ability to handle the rough conditions that bluewater cruisers encounter, while still remembering she achieves noteworthy speeds. We've created a blend of timeless elegance and contemporary charm.

One design feature that stands out is an array of available aft configurations. These options cater to a variety of cruising and entertaining needs, whether an owner is seeking additional storage, a crew cabin, or an open aft deck area suitable for parties or intimate gatherings. The yacht can be personalized to match each owner's unique requirements, while maintaining a practical utility.

Sirena Marine
Design Team

**“We’ve
created a
blend of
timeless
elegance and
contemporary
charm.”**



SIRENA 48

Since prospective owners have certain ideas about how they will use their next yacht, we have created a wealth of choices to ensure they see the full range of possibilities of cruising on the Sirena 48. With four different layouts for the aft deck and transom area, our newest yacht has something for everyone. Configurations include a huge storage locker opening onto the swim platform to manage all manner of water toys and gear, and this option can also be configured with a foldout bench seat on the swim platform. Another choice swaps out the forward-facing transom settee for an appealing aft-facing lounge area with cocktail table. Still another possibility is to add a crew's quarters, with berth and private head.

Choice is a hallmark of our brand, and Sirena 48 buyers can select the layout that works best for their cruising needs. Equipped with a hull that's ready to transit blue water stretches without concern, or motor briskly from port to port on a coastal sojourn, the Sirena 48 delivers on the promise of voyaging variety for cruisers looking for more choices in a single boat—one that will meet the needs of their busy schedules and yet let them truly escape from the concerns of their lives and into a world laid at their feet.



SIRENA YACHTS







AFT DECK

Luxury, Uninterrupted

The Sirena 48 stays true to the guiding concept of comfort throughout her design, and nowhere are these principles more readily apparent to the visitor than the aft deck. Simply put this cruiser brings together many avenues of delight in a simple, understated space. There are boarding gates to both port and starboard, as well as easy access to the swim platform, where guests will arrive by tender or launch. The aft deck is also a key option point for prospective owners to consider, with four arrangements available, including such features as crew's quarters, a folding seat for the swim platform, additional storage, a wide transom bench, and the open option (shown),

which relinquishes the portside stern stairs to free up deck space. Available seating options abound but a pair of moveable love seats allows for flexibility around a fixed-position folding table, all convenient to the wide-opening saloon bulkhead, where the aft galley is in perfect position to provide refreshment. Beyond that, the views are hard to beat, a cooling swim is right at hand, and a view of approaching visitors, as well as guests circulating around the yacht.







SWIM PLATFORM

Get Closer to the Sea

To be surrounded by the sea is one thing, but to touch it, swim in it, and feel its cooling waters with ease, any time—that's a true luxury. The Sirena 48 swim platform can submerge hydraulically to simplify swimming, or stay above, within easy reach of the undulating surface.

 **SIRENA 48**



FORE DECK

Fun and Frolic

What's on the horizon? Nothing that a sunpad and bench seat can't beat, when they're on the foredeck of the Sirena 48. At anchor, cool breezes caress sun-kissed bodies enjoying a quiet anchorage, surrounded by wide deck areas replete with sturdy safety rails, allowing guests to [safely] multiply the drama of any onboard party.





FLYBRIDGE

Takes Off

The Sirena 48 masters all the concepts of the Sirena Yachts range, and the excitement of a flybridge has been a key element of the line since its inception. While this yacht borrows many features from her elder sisters, she remakes the flybridge concept as a true original. One visit to the top deck and prospective owners will know exactly what they want. The helm station is placed at the center of the action, so the skipper can enjoy the company of friends on the sunpad forward or be within earshot of the conversation on the aft settee. Folding tables heighten the utility of the lounge seating, making it easy for more people to get in and out. The finely finished hardtop

is built on a center pedestal, with polished tubular supports to either side, and has LED lights built into the overhead, stretching the hours that the flybridge can be used safely. Built into the helm seat is an alfresco galley setup, with an electric grill, storage lockers for cookware and serving gear, and a refrigerator. Stairs to starboard lead to the aft deck, with welded railings simplifying safe passage.





SIRENA YACHTS

Interior

Designer Quote

About the Interior

From scratch to the finished yacht, throughout the process we aimed for the interior to reveal the essence of the Sirena 48, a concept that unites customer value with well-found user experience. We wanted to locate a balance of facilities that would offer wide adaptability to the owners' needs.

That meant the yacht had to be comfortable to get around and offer plenty of storage. The yacht's hull design and exterior elements generate large interior volumes filled with light and airy space. The Sirena 48 interior uses fluid interior surfaces and transitions to give the user a roomy and coherent feeling. The décor pack consists of two contrasting selections that each lend an air of softness and contribute to a cozy feeling.

Sirena Marine
Design Team



“The yacht had to be comfortable to get around and offer plenty of storage.”



Leonardo



SALOON

The first thing one notices upon entering the main saloon is the enormous windows that feel like the whole world lay at one's feet. A U-shaped lounge with a folding table is located to port ensuring the skipper will never be lonely. An aft galley arrangement is convenient to keep the whole crew fed, whether they are inside or enjoying the aft deck.

VIP STATEROOM

For truly treasured guests, the obvious choice is the bow VIP stateroom. Here the vaunted volume of the Sirena hull design delivers a comfortable space with bright natural light through generous hullside windows, soft textures and calming colors, a welcoming, queen-size berth situated at a proper height, and a delightful combination of roomy decks for easy footing and plenty of headroom.





MASTER STATEROOM

The Sirena 48 owner's stateroom is, quite rightfully, the peak of onboard comfort. Centrally located and low in the hull, the king-size berth receives the most gentle movement of the sea. The appointments are fit for a yacht owner, with hullside windows and opening ports, drawers and lockers for storage, relaxing lounge seating, a private head compartment, and fine finishes and fabrics.

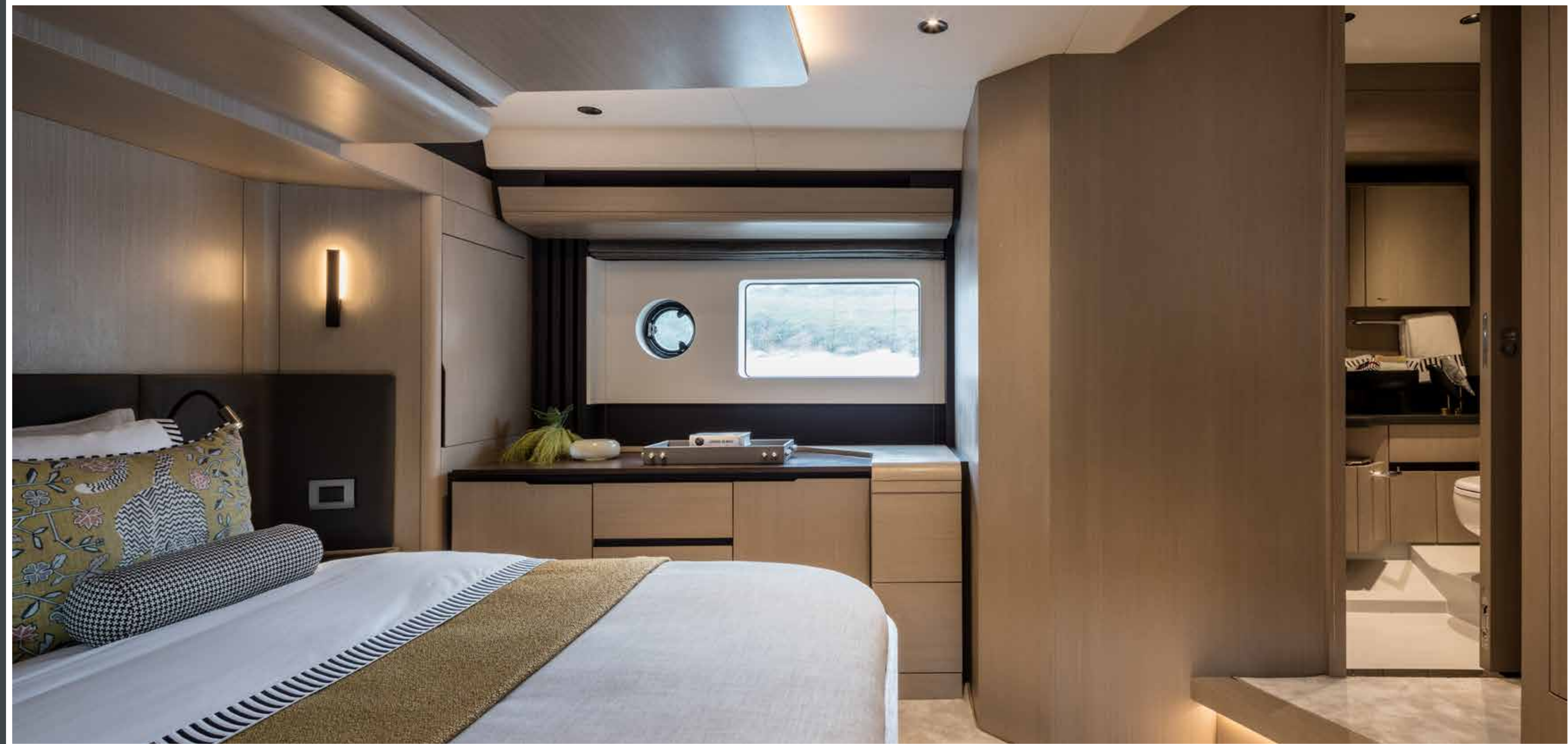

QUIET COMFORT

The starboard guest double stateroom offers the same level of fit and finish as the rest of the interior accommodations, and likewise benefits from the excellent hull volume and design to offer comfort in an efficient space with standup headroom and a hanging locker. As in all Sirena Yachts, natural and manmade light combine to welcome guests to their own serene escape.

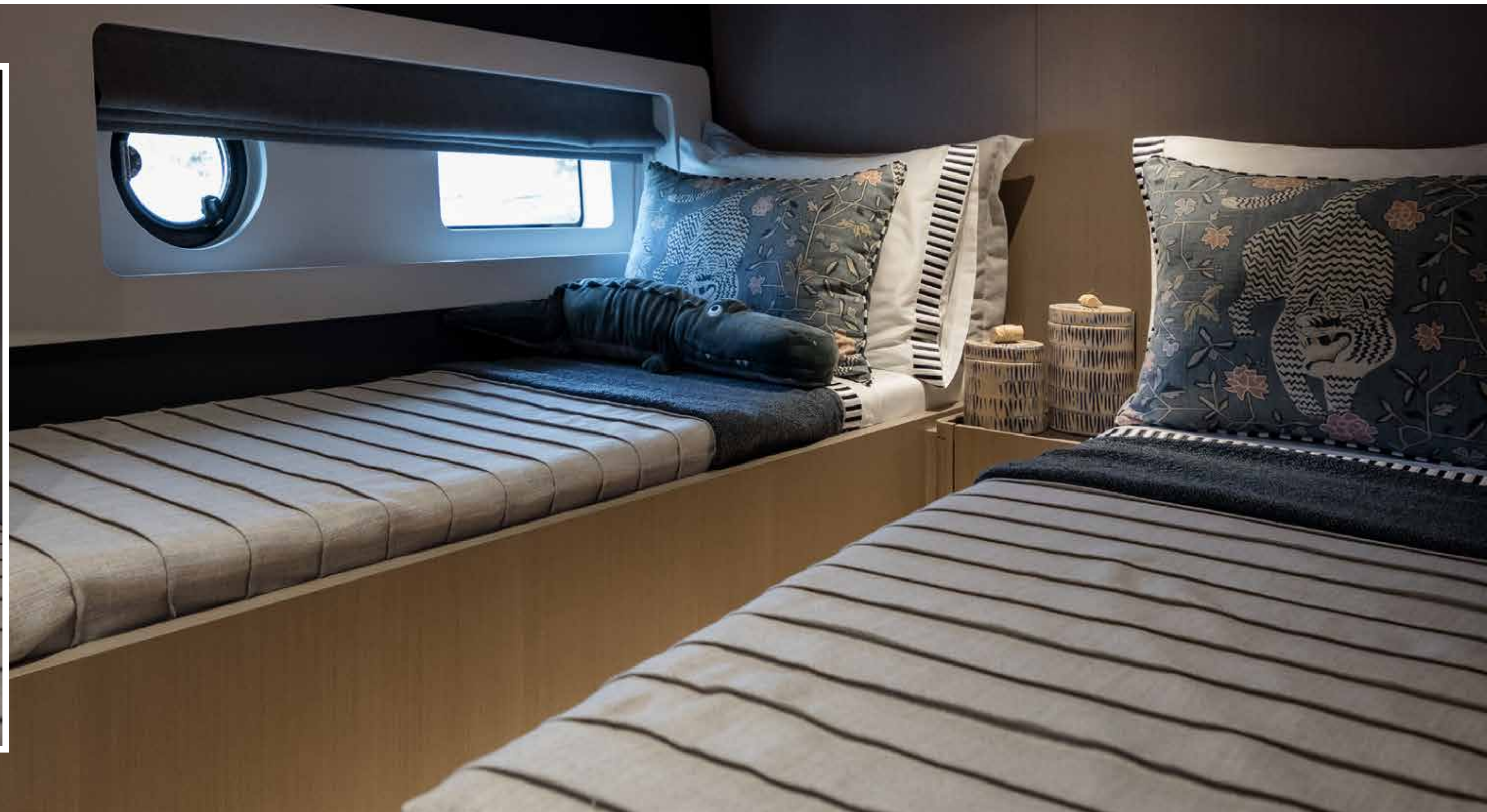
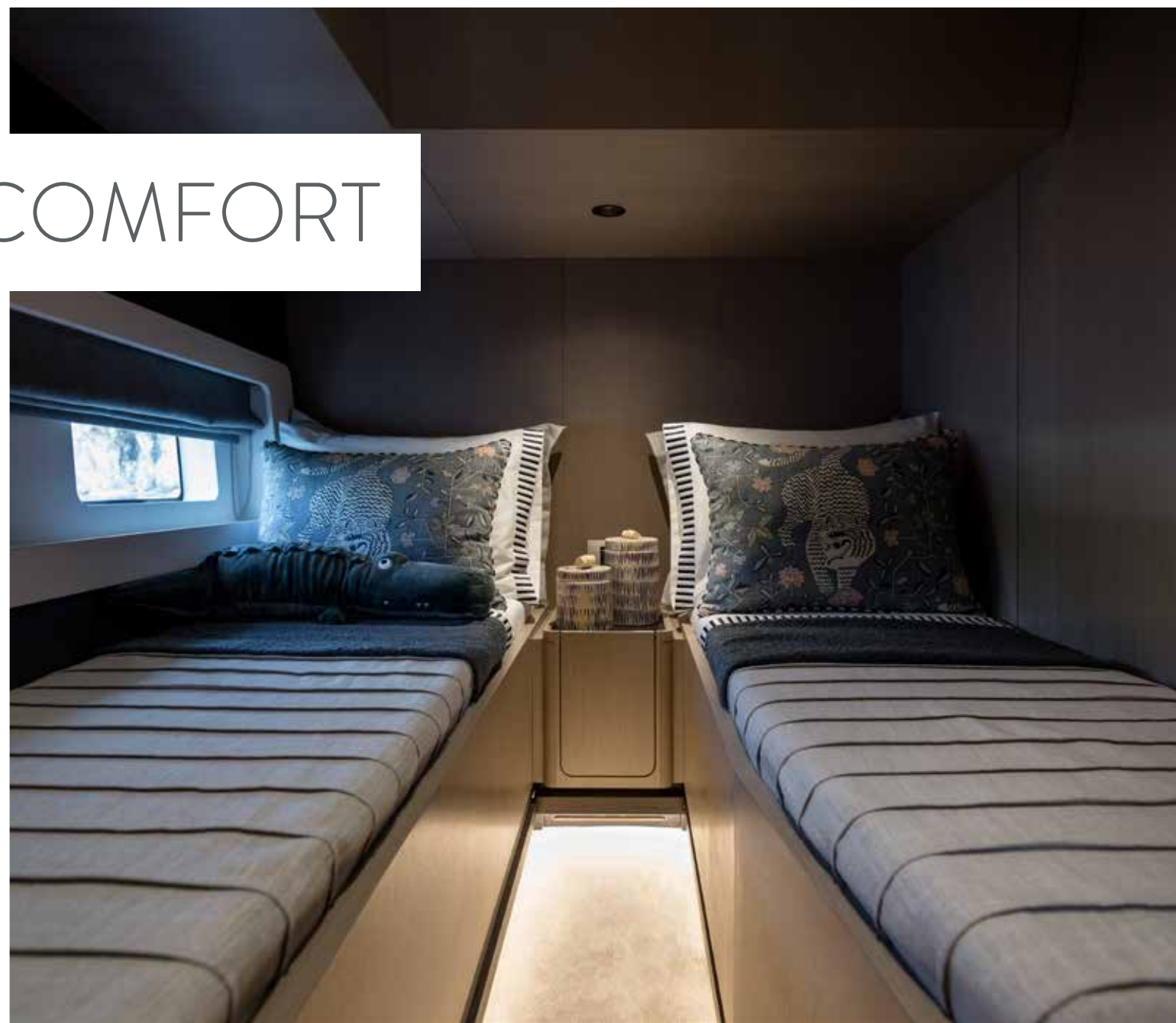



ADVANCED TECHNOLOGY

Creating a hull design that is efficient and offers a range of speeds has been part of the Sirena Yachts plan from the beginning. To that end, a finely crafted yacht has specific needs for hull stiffness, overall hull weight, and a durable, long-lasting finish. Technology has been a core component of the strategy of Sirena Yachts since the company's inception. The use of carbon fiber offers lightweight strength and stiffness in our hulls. If a boatbuilder does not have the advanced techniques to employ these next-generation materials, the benefits of using

them are wasted. Sirena Yachts craftsmen understand the use of carbon in conjunction with resin infusion, which uses vacuum-bagging to add the precise measurement of resin for the hull and parts to have the ideal balance of strength and weight. While some companies leave carbon fiber exposed as an ostentatious display of its use, we include it quietly, beneath the fine finish that sets apart our yachts. Craftsmanship is in the doing, and at Sirena Yachts, our artisans and craftsmen understand the importance of making timeless yachts.



The Soft Sell

The marine environment is beautiful but it is a hard place to succeed consistently, particularly when it comes to soft goods, and it will challenge your preconceived notions and your courage at every turn. Designing fabrics to be used on a yacht means creating something astonishingly beautiful that will catch the eye and glint in the sun, while also standing up to moisture and hard wear.



Trick of the Eye

Creating a space on board that makes people feel comfortable and welcome is not an easy task. Making every space on a yacht deliver that level of appeal may seem to be downright impossible. Smart design means using the space available to achieve a desired result, and in ways that are consistent and flow into one another seamlessly.



Crafting a Heritage

When one thinks of a yacht-building heritage such as that of Turkey, the past plays a large role. But craftsmanship is as much about adapting the ways of the future to the challenges of today. Our craftsmen synthesize the strengths of the old ways and the intelligence of the new, making the latest creations something that people can enjoy, knowing they've never seen it before.



THE FUTURE OF CRAFTSMANSHIP

The history of boatbuilding in Turkey stretches back for millennia, and craftsmanship continues to play a large role in the process, from start to finish. Just as yachts keep evolving in every way, from cruising capabilities to efficiency to the level of onboard comfort, so have yacht owners' expectations moved in similar directions. Sirena Yachts is uniquely positioned to accommodate these parallel vectors, nurturing relationships with several of the foremost yacht designers, naval architects, interior experts, and marine engineers working in the world today. The imprimatur these industry leaders bring to every design is backed up by their many years of experience, and is readily visible in numerous projects still gracing seas around the world, and we have enjoyed a fruitful partnership with each of them. One example is Germán Frers, who has designed several of our Sirena Yachts models (as well as some of the sailing yachts in the Sirena Marine stable). His firm worked with us on

the hull design of the Sirena 48, resulting in the efficiency of long range at a 10-knot cruise, but also the possibility of top speeds reaching 27 knots—a spectrum of speed that creates cruising possibilities. But all of those possibilities are relatively meaningless if a boat does not capture the heart as well as the mind of the owners and those they welcome aboard. Quality construction can deliver comfort through lines of sight, creative use of lighting, and the very best materials and fabrics, which enhance the overall feel. We also augmented efficiencies in our process as well, by bringing the means of production into our boatyard. It's the best way to ensure that yacht construction can happen on our timetable—rather than waiting on a supplier to provide stainless steel components, for example, we have our own foundry at the yard, where we can craft exactly what we need, to our exact specification. While it may seem a substantial investment, it pays dividends as we have grown.

LAYOUT OPTIONS

Standard Layout

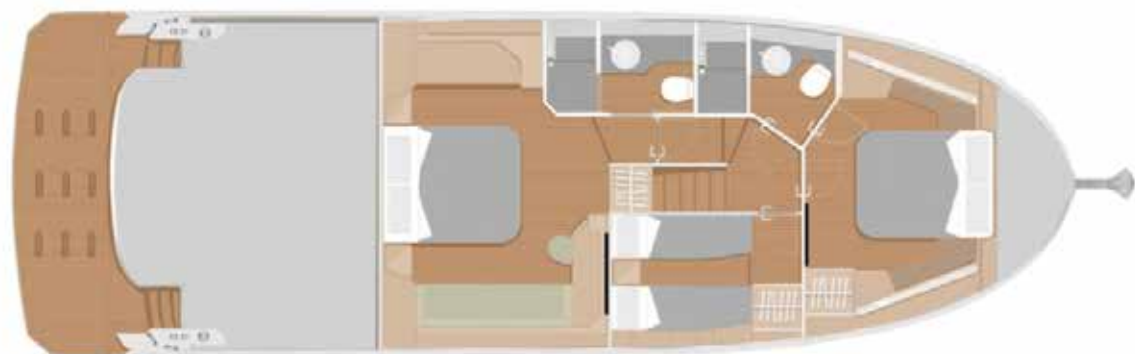

LAYOUT OPTIONS

Optional Layout

Crew Cabin Option

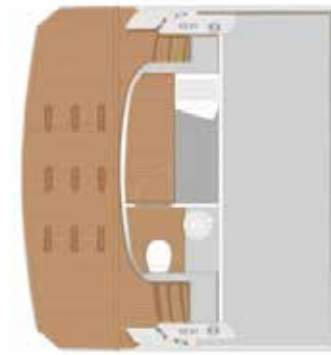

Foldable Seat with Storage Option

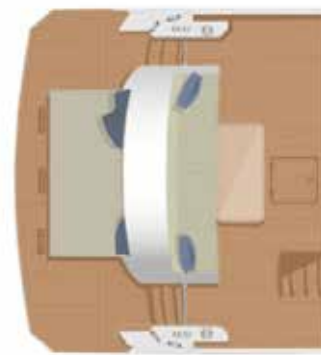

Large Storage Option

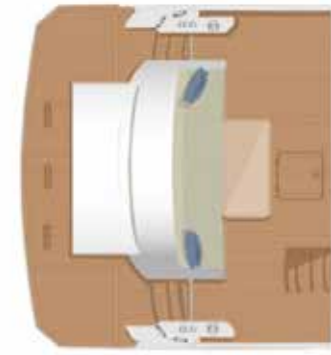

Open Aft Option



Dimensions and Main Characteristics

Length Overall L _{OA} (Incl. swim platform anchor roller)	16.04 m / 52'7 _{1/2} "
Hull Length L _H ISO 8666 (Net GRP - Swim platform excluded)	13,79 m/ 45'3"
Waterline Length L _{WL} ISO 8666 (Full load conditions)	13,76 m / 45'2"
Hull Beam B ISO 8666 (@ Mid-ship section)	5 m / 16'5"
Max Draft - T ISO 8666	1,05 m / 3'5"
Loaded-Displacement Mass - ISO 8666	27,24 tonnes / 60053 lbs (with Cummins QSB 6.7) 28,76 tonnes / 63404 lbs (with VOLVO D11)
Light Craft Condition Mass - m _{LCC ISO 8666} (= Dry displacement, no crew, no luggage)	23,42 tonnes / 45145 lbs (with 2 x Cummins QSB 6.7) 24,9 tonnes / 54983 lbs (with 2 x VOLVO D11) - optional
Diesel Tank Capacity	1900 lt / 502 gal
Fresh Water Tank	600 lt / 159 gal
Black Water Tank Capacity	300 lt / 79 gal
Gray Water Tank Capacity	240 lt / 63 gal
Cabins	3 standard + 1 (optional crew cabin)
Beds	6 + (1 crew)
Heads	2 + 1 (crew head)
Building Material	GRP
Hull Type	Semi-Displacement
Exterior Styling & Concept	Sirena Marine
Interior Decor	Sirena Marine
Hull Design	German Frers
Engines	Cummins QSB 6.7 550 HP x 2 VOLVO D11 670 HP x 2 - optional
Marine Gears	ZF 280 IV (Cummins QSB 6.7) ZF 325 IV (VOLVO D11) - optional
Reduction Ratio	2.0:1 - ZF 280 IV 2.037:1 - ZF 325 IV - optional
Transmission	V Drive
Propeller Diameter (Max)	700 mm / 2'355"
Max Speed*	24 knots 27,5 knots (with VOLVO D11 670 HP x 2 - optional)
Cruising Speed	16 knots
Economy Cruising Speed	10 knots
Range 10 kn (Incl. 10% reservoir)*	477 NM
Certification	CE Category B

*NOTE: All performance specified in the table above are design data and applies to a standard configuration boat (standard equipment installed as per this standard list) with clean keel, propellers, and rudders. Furthermore, the performance levels indicated above have been defined under good sea and wind conditions (Beaufort Scale level 1, Douglas Scale level 1, ambient T < 25°C, seawater T=15°C, atmospheric P=103250 Pa) with 2 people on board, 25% fuel, and fresh, grey and black water tanks empty. Different or harsher sea conditions and additional selected optional equipment may affect the performance.



SIRENA YACHTS

TR

Turkey, Headquarters

+90 212 219 74 74

Abdi İpekçi Cad. Ada Apt. No: 22/18
K: 5 34367 Nişantaşı / İstanbul

sales@sirenayachts.com
www.sirenayachts.com

SIRENA MARINE